



331G / 333G SPECIFICATIONS

Engine	331G	333G
Manufacturer and Model	Yanmar 4TNV94FHT	Yanmar 4TNV94CHT
Non-Road Emission Standards	EPA Final Tier 4/ EU Stage IV	EPA Interim Tier 4/ EU Stage IIIB
Cylinders	4	4
Gross Rated Power (ISO 14396)	68.0 kW (91.2 hp) at 2,500 rpm	74.6 kW (100 hp) at 2,500 rpm
Net Peak Power (SAE J1349 / ISO 9249)	66.0 kW (88.5 hp) at 2,500 rpm	72.0 kW (96.6 hp) at 2,500 rpm
Peak Torque	382 Nm (281.8 ft.-lb.) at 1,700 rpm	395 Nm (291.3 ft.-lb.) at 1,700 rpm
Displacement	3.1 L (186.3 cu. in.)	3.1 L (186.3 cu. in.)
Rated Engine Speed	2,500 rpm	2,500 rpm
Torque Rise	47% at 1,700 rpm	39% at 1,700 rpm
Aspiration	Turbocharged, intercooled	Turbocharged, intercooled
Air Cleaner	Dry dual element	Dry dual element
Cooling	331G / 333G	
Fan Type	Variable-speed hydraulic drive standard / reversing fan drive optional	
Powertrain	331G	333G
Pump	Axial-piston hydrostatic	Axial-piston hydrostatic
Controls	Electrohydraulic	Electrohydraulic
Travel Speeds		
Low	8.5 km/h (5.3 mph)	8.5 km/h (5.3 mph)
High	12.6 km/h (7.8 mph)	12.6 km/h (7.8 mph)
Brakes	Integral, automatic, spring-applied, hydraulically released wet-disc brake	
Undercarriage	Rubber Tracks	
	Smooth-ride long-life rubber with steel inserts	
Track Width		
Standard	400 mm (15.8 in.)	450 mm (17.7 in.)
Optional	450 mm (17.7 in.)	400 mm (15.8 in.)
Ground Pressure		
400-mm (15.8 in.) Track (standard on 331G / optional on 333G)	38.1 kPa (5.5 psi)	38.4 kPa (5.6 psi)
450-mm (17.7 in.) Track (optional on 331G / standard on 333G)	33.9 kPa (4.9 psi)	34.1 kPa (5.0 psi)
Track Rollers (per side)	5 triple-flange smooth-ride all-steel rollers	5 triple-flange smooth-ride all-steel rollers
Track Idlers (per side)	2 double-flange smooth-ride all-steel rollers	2 double-flange smooth-ride all-steel rollers
Bearings/Seals (rollers/idlers)	Heavy-duty journal bearings and metal face seals	Heavy-duty journal bearings and metal face seals
Tractive Effort	5221 kgf (11,500 lbf)	5221 kgf (11,500 lbf)
Hydraulics		
Pump Flow		
Standard	80 L/m (23.5 gpm)	95 L/m (25.0 gpm)
Total with High-Flow Option	138 L/m (36.5 gpm)	156 L/m (41.1 gpm)
System Pressure at Couplers	23 787 kPa (3,450 psi)	23 787 kPa (3,450 psi)
Hydraulic Horsepower Flow (calculated)		
Standard	35 kW (47 hp)	38 kW (50 hp)
High	55 kW (74 hp)	62 kW (83 hp)
Cylinders	331G / 333G	
Type	John Deere heat-treated, chrome-plated, polished cylinder rods, hardened steel (replaceable bushings) pivot pins	
Electrical		
Voltage	12 volt	
Battery Capacity	925 CCA	
Alternator Rating	90 amp	
Lights	Halogen: 2 front and 1 rear standard / deluxe LED: 4 front and 1 rear optional	
Operator's Station	ROPS (ISO 3471) / FOPS (ISO 3449) structure with quick-pivot standard	
Serviceability		
Refill Capacity		
Fuel Tank	114 L (30 gal.)	

331G / 333G SPECIFICATIONS



Operating Weight	331G		333G	
	<i>EPA Final Tier 4/ EU Stage IV</i>	<i>EPA Interim Tier 4/ EU Stage IIIB</i>	<i>EPA Final Tier 4/ EU Stage IV</i>	<i>EPA Interim Tier 4/ EU Stage IIIB</i>
With Standard 400-mm (15.8 in.) Track	5403 kg (11,900 lb.)	5357 kg (11,800 lb.)	—	—
With Standard 450-mm (17.7 in.) Track	—	—	5493 kg (12,100 lb.)	5448 kg (12,000 lb.)
Machine Dimensions	331G / 333G			
A Length without Bucket	3.10 m (122 in.) (10 ft. 2 in.)			
B Length with Foundry Bucket	3.71 m (146 in.) (12 ft. 2 in.)			
C Width without Bucket	2.00 m (78.9 in.) (6 ft. 7 in.)			
With 400-mm (15.8 in.) Track	2.00 m (78.9 in.) (6 ft. 7 in.)			
With 450-mm (17.7 in.) Track	2.05 m (80.7 in.) (6 ft. 9 in.)			
D Height to Top of ROPS	2.20 m (86.7 in.) (7 ft. 3 in.)			
E Height to Hinge Pin	3.35 m (132 in.) (11 ft. 0 in.)			
F Dump Height with Foundry Bucket	2.69 m (106.1 in.) (8 ft. 10 in.)			
G Dump Reach	0.71 m (28 in.)			
With Foundry Bucket	0.71 m (28 in.)			
With Construction Bucket (no edge)	0.88 m (34.6 in.)			
H Ground Clearance	0.24 m (9.4 in.)			
I Angle of Departure	31 deg.			
J Front Turn Radius with Foundry Bucket	2.18 m (85.7 in.) (7 ft. 2 in.)			
K Dump Angle (full lift height)	48 deg.			
L Bucket Rollback (ground level)	35 deg.			

331G / 333G COMPACT TRACK LOADERS

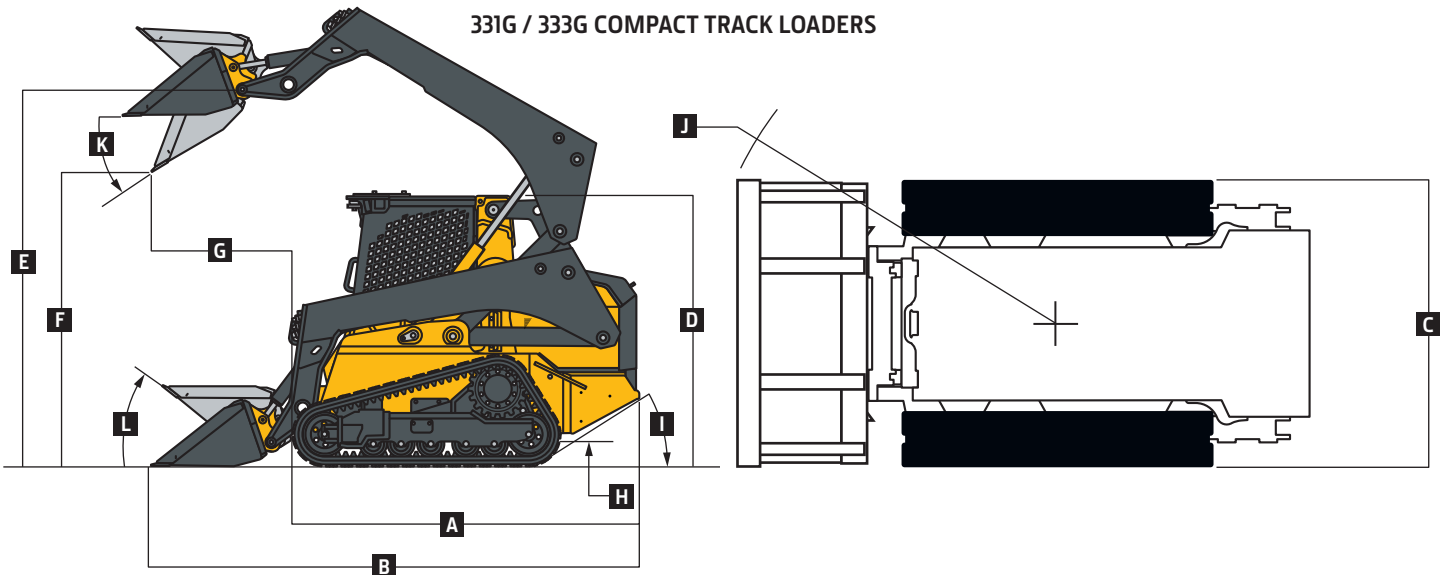

Loader Performance	331G	333G
	<i>EPA Final Tier 4/EU Stage IV and EPA Interim Tier 4/EU Stage IIIB</i>	<i>EPA Final Tier 4/EU Stage IV and EPA Interim Tier 4/EU Stage IIIB</i>
Tipping Load with Foundry Bucket	4021 kg (8,857 lb.)	4799 kg (10,570 lb.)
SAE Rated Operating Capacity		
At 35% Tipping Load	1407 kg (3,100 lb.)	1680 kg (3,700 lb.)
At 50% Tipping Load	2011 kg (4,429 lb.)	2399 kg (5,285 lb.)
Boom Breakout Force		
With Foundry Bucket	2724 kg (6,000 lb.)	3746 kg (8,250 lb.)
With Construction Bucket	2724 kg (6,000 lb.)	3519 kg (7,750 lb.)
Bucket Breakout Force		
With Foundry Bucket	4688 kg (10,325 lb.)	6243 kg (13,750 lb.)
With Heavy-Duty Construction Bucket	3450 kg (7,600 lb.)	4200 kg (9,250 lb.)

Additional equipment

Key: ● Standard ▲ Optional or special

See your John Deere dealer for further information.

325G	331G	333G	Engine
●	●	●	Meets EPA Final Tier 4/EU Stage IV emissions
▲			Meets EPA Interim Tier 4/EU Stage IIIA emissions
	▲	▲	Meets EPA Interim Tier 4/EU Stage IIIB emissions
●			Yanmar 4TNV98CT
▲			Yanmar 4TNV98T
	●	●	Yanmar 4TNV94FHT
	▲	▲	Yanmar 4TNV94CHT
●	●	●	Auto-idle
●	●	●	Automatic fan tensioner
●	●	●	Automatic preheat
●	●	●	Electronic injection system
▲	▲	▲	Engine air precleaner kit
●			Fuel tank, 79 L (21 gal.)
	●	●	Fuel tank, 114 L (30 gal.)
●	●	●	John Deere COOL-GARD™ II Extended-Life Engine Coolant
●	●	●	John Deere Plus-50™ 10w30 initial engine oil fill ⁶
●			4-cylinder 54.8 kW (74 gross hp)/52.5 kW (70 net hp), 3.3-L (203 cu. in.) displacement
	●		4-cylinder 68.0 kW (91.2 gross hp)/66.0 kW (88.5 net hp), 3.1-L (186.3 cu. in.) displacement
		●	4-cylinder 74.6 kW (100 gross hp)/72.0 kW (96.6 net hp), 3.1-L (186.3 cu. in.) displacement
●	●	●	5-micron primary fuel filter and water separator
▲	▲	▲	Cold-weather starting package
Cooling System			
●	●	●	Coolant surge tank
●	●	●	Variable-speed hydraulically driven fan cooling system
▲	▲	▲	Reversing fan drive
Powertrain			
●	●	●	High-torque heavy-duty planetary-reduction final drive
●	●	●	Automatic spring-applied hydraulically released wet-disc park brake
●	●	●	Wet-disc brakes
●			Transmission, single speed
▲	●	●	Transmission, 2 speed
Hydraulic System			
●	●	●	John Deere hydraulic cylinders with cushioned boom cylinders
●	●	●	John Deere heat-treated, chrome-plated cylinder rods with replaceable bushings
●	●	●	Connect-under-pressure auxiliary couplers
●	●	●	Quick-check hydraulic fluid-level sight glass
●	●	●	1,000-hour, 5-micron hydraulic filter

325G	331G	333G	Hydraulic System (continued)
▲	▲	▲	High-flow hydraulics
●	●	●	Axial-piston hydrostatic pump
Electrical			
●	●	●	Automatic engine/hydraulic shutdown protection system
●	●	●	Auxiliary hydraulics operator-presence system
●	●	●	Courtesy lighting
●	●	●	Deluxe instrumentation EMU with: Operator-selectable monitoring – Hour meter, engine rpm, battery voltage, diagnostics, EMU configuration, engine coolant temperature, hydraulic oil temperature / LED warning indicators – Glow plug, seat switch, seat belt, door open, auxiliary hydraulics, park brake engaged, 2-speed engaged, stop, low engine oil pressure, engine coolant over-temperature, battery not charging, air filter restriction, and hydraulic filter restriction
▲	▲	▲	Deluxe LED lighting package with additional cab-integrated side lights (2)
●	●	●	Front and rear halogen work lights
●	●	●	Triple-interlock operator-presence control system
●	●	●	Backup alarm
●			Battery, 750 CCA
▲	●	●	Battery, 925 CCA
●	●	●	Horn
▲	▲	▲	Hazard warning lights
▲	▲	▲	Strobe light, amber
Operator's Station			
●	●	●	Deluxe cab headliner
●	●	●	Electrohydraulic (EH) ISO-pattern joystick controls
▲	▲	▲	ISO-H switchable joystick controls and EH joystick performance package*
	▲	▲	EH 4-way switchable controls include EH foot control, ISO joystick control, H-pattern joystick control, and ISO and foot controls
	▲	▲	ISO controls with programmable detents and EH boom performance package; ¹ also includes EH joystick performance package*
	▲	▲	Onboard grade indication: Grade-control option delivers onboard readout within LCD monitor that provides slope of blade (cross-slope direction) and mainfall (fore/aft direction) within ±0.5-percent accuracy
▲	●	●	Keyless-start sealed-switch module with integrated anti-theft system and operator memory preference settings
●	●	●	Electronic push-button auxiliary controls
●	●	●	Pull-down adjustable lap bar
●	●	●	Quick-pivot ROPS
●	●	●	Rear window

325G	331G	333G	Operator's Station (continued)
●	●	●	Removable top window
▲	▲	▲	Sliding/locking/removable glass side windows
●	●	●	ROPS/FOPS operator structure
▲	▲	▲	Glass cab enclosure
●	●	●	Seat belt, 51 mm (2 in.), retractable
▲	▲	▲	Shoulder belt, 51 mm (2 in.) or 76 mm (3 in.)
▲	▲	▲	Severe-duty cab door and wiper system
●	●	●	Water-shedding deluxe vinyl suspension seat
▲	▲	▲	Air-ride cloth, heated seat
▲	▲	▲	Air-ride vinyl seat
●	●	●	12-volt power port / Dome light / Cargo storage / Beverage holder
▲	▲	▲	Air conditioning with heater/defroster
▲	▲	▲	AM/FM radio with auxiliary input and Bluetooth® for audio streaming
▲	▲	▲	Floor mat with left footrest
●	●	●	Rearview mirror
▲	▲	▲	Rearview camera
Loader			
●	●	●	In-cab boom lockout to secure loader before exiting seat
●	●	●	Patented John Deere Quik-Tatch™ (no grease required)
▲	▲	▲	Power Quik-Tatch
●	●	●	Patented John Deere vertical-lift boom
▲	▲	▲	Hydraulic self-leveling on/off and ride control
Other			
●	●	●	Convenient front and rear tie-downs
●	●	●	Environmental drains for all fluid reservoirs
▲	▲	▲	Chrome exhaust stack
▲	▲	▲	Engine oil/hydraulic fluid-sampling kit
▲	▲	▲	Forestry protection packages
▲	▲	▲	Heavy-duty rear grille
▲	▲	▲	Rear counterweights (available in sets of 1, 2, or 3), 78 kg (172 lb.) (each set)
▲	▲	▲	Single-point lift kit
▲	▲	▲	SMV sign kit
●			Track, 320-mm (12.6 in.) wide
▲	●	▲	Track, 400-mm (15.8 in.) wide
	▲	●	Track, 450-mm (17.7 in.) wide
▲	▲	▲	JDLINK™ wireless communication system (available in specific countries; see your dealer for details)

⁶500-hour engine oil-change intervals when John Deere Plus-50 oil and John Deere oil filter are used.

*EH joystick performance package features switchable accelerator/decelerator, selectable propel speeds, creep control, boom- and bucket-speed settings, and 12-volt 3- and 14-pin attachment-control harness with dash-mounted 4th-function rocker switch.

¹EH boom performance package features include EH bucket self-level up and down, return to dig, return to carry, and boom-height kick-out.

Net engine power is with standard equipment including air cleaner, exhaust system, alternator, and cooling fan, at standard conditions per SAE J1349 and DIN 6270B, using No. 2-D fuel at 35 API gravity. Gross power is without cooling fan. Specifications and design subject to change without notice. Wherever applicable, specifications are in accordance with SAE standards. Except where otherwise noted, these specifications are based on units with standard equipment, full fuel tanks, and 79-kg (175-lb.) operator.

